

Thank you

FOR YOUR
INTEREST IN
CORWIN

Please enjoy this complimentary excerpt from *Teaching Mathematics in the Visible Learning Classroom, High School* by John Almarode, Douglas Fisher, Joseph Assof, John Hattie, and Nancy Frey. Featured is a PAR, Peer-Assisted-Review, on understanding volume formulas. PAR's are a great resource to help students reflect on their own thinking and solve meaningful problems.

[LEARN MORE](#) about this title, including Features, Table of Contents and Reviews.

PEER-ASSISTED REFLECTION FOR VOLUME FORMULAS

Peer-Assisted Reflection

Name: _____

Period: _____

Date: _____

Write your solution in the left column. The right column is used for annotations. If you provide feedback to your peer, you will annotate their solution. After class, you will annotate your own solution as well. In your submission, use the annotation column to explain how you did (or didn't) respond to peer feedback.

PAR 4.1: Volume Formulas

Success Criteria

- I can identify the volume formulas for various types of prisms and explain their meaning.
 - I can identify the volume formulas for various types of pyramids and explain their meaning.
1. Write a formula that can be used to find the volume of the object that follows. Label each component and explain why it is necessary.

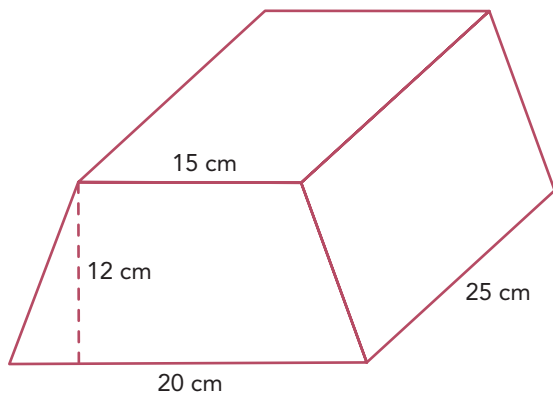

2. Calculate the volume using your formula.
3. Write and label a volume formula for this object as if it had the same base and height, but instead came to a point on one end. Justify your reasoning.

Reviewed by: _____

Rate your peer's mastery of the success criterion (this is the last thing you do):

- I can identify the volume formulas for various types of prisms and explain their meaning.

0—DO NOT check that box	1—ALMOST check that box	2—CHECK that box
Many mathematical errors and/or incomplete or unclear annotations	Few mathematical errors and/or somewhat incomplete or unclear annotations	No mathematical errors and perfectly complete and clear annotation

- I can identify the volume formulas for various types of pyramids and explain their meaning.

0—DO NOT check that box	1—ALMOST check that box	2—CHECK that box

DRAFT SOLUTION

ANNOTATIONS (author's *and* peer's)

REVISED SOLUTION

ANNOTATIONS (author only)

Figure 3.6



This peer-assisted reflection task is available for download at resources.corwin.com/vlmathematics-9-12.

Teaching Takeaway

Although homework has an overall effect size of 0.29, in the secondary classroom the effect size is 0.64.

Teaching Takeaway

Once students have the foundational knowledge about specific mathematics content, inquiry-based teaching supports the making of connections between concepts and ideas.

EFFECT SIZE FOR
PEER TUTORING
= 0.53

EFFECT SIZE FOR
SPACED PRACTICE
VERSUS MASS
PRACTICE = 0.60

Peer-assisted reflection (PAR) is a collaborative protocol that requires students to

1. Work on meaningful problems
2. Reflect on their own work
3. Analyze a peer's work and exchange feedback
4. Revise their work based on insights gained throughout this cycle

(Reinholz, 2015)

Mr. Wittrock accompanies every new lesson with a PAR task aligned to the day's success criteria as part of a formative assessment cycle. His intent is to transfer his teacher clarity into student clarity through this iterative feedback cycle. Over the course of the next few days, students will revisit these success criteria multiple times through the problems assigned in the PAR task. As their homework tonight, they must complete a draft solution—along with annotations explaining their thought process (not just *what* they did, but *why* they did it)—that is ready to be reviewed at the start of class tomorrow.

Tomorrow, they will exchange drafts with a peer and offer feedback in two phases. First, peers provide each other written feedback in the form of annotations and a rating toward mastery of each success criterion during a silent review phase. Mr. Wittrock likes to justify this phase by telling students, “We need to get to the point where our work speaks for itself. We want to make sure that the grader has no choice but to interpret our work the way we intend.” Second, peers discuss the written feedback they provided and ask any clarifying questions they might have. The final step for students is to revise their draft solution into a final submission and include a reflection of how their thinking changed throughout this process. Mr. Wittrock scores these final submissions, collects the formative data they provide, and responds based on the results.

There are a number of benefits baked into this practice Mr. Wittrock uses. One is that students become greater academic risk takers because of the iterative nature of PAR assignments from draft to feedback to revision.

As one student put it, “How does one fail a draft?” Another benefit is the metacognitive process of students annotating their own work, receiving feedback, and then revisiting that same work. Yes, this is spaced practice of content as students revisit the same problems multiple days in a row; but it is also spaced practice in service of deeper thinking about one’s own thinking as students work to revise and solidify their own understanding and thought processes. The formative data generated by the process is also very valuable for Mr. Wittrock. By the end of each PAR cycle, he has specific data about which students have met which success criteria. He can use this to design rotation stations, small-group instruction opportunities, whole-class reviews, or whatever else might be called for by the data.

The most important reason that Mr. Wittrock uses the PAR system, however, is to provide students actionable feedback (often delivered by peers) that they can use to further take control of their own learning and develop into assessment-capable visible learners. Student self-efficacy garnered through the process is priceless, as it truly puts them *in the know* about their own learning. The PAR cycle gives students the opportunity to compare and contrast: *This is what I used to be able to do; this is what I can do now. This is how I used to think about this problem; this is how I think about it now. This is what I used to know; this is what I know now.*

In addition to these before-and-after snapshots, the feedback and annotation components of PARs can collect much of the connective tissue that bridged students from where they were to where they are. In other words, not only does growth as an outcome become blatant to students, but students become aware of their own growth process as well. Figure 3.7 shows how Mr. Wittrock made his planning visible so that he could then provide an engaging and rigorous learning experience for his learners..



Video 10 Feedback Through Peer- Assisted Reflection

<https://resources.corwin.com/v/mathematics-9-12>

EFFECT SIZE FOR
METACOGNITIVE
STRATEGIES = 0.60

EFFECT SIZE FOR
ASSESSMENT-
CAPABLE VISIBLE
LEARNERS = 1.33

Teaching Takeaway

Conceptual understanding can also be at the surface phase of learning. This occurs when learners are initially developing conceptual understanding.